

EHF Rulebook

Edition 2010

EHF – Rulebook - 2010

(replaces all former versions; updated in December 2009)

SUMMARY:

1. EHC – an EHF Sanctioned Competition	page 3
2. Classification	page 3
3. Time Keeping and Start Numbers	page 4
4. Individual ranking	page 4
5. Team ranking	page 5
6. Handbike equipment	page 6
7. Safety	page 6
8. Races	page 6
9. Penalties	page 7
10. Prize money	page 7
11. U23 Athletes	page 8
12. Exclusion of liability	page 8
Appendix A (Drafting Rule)	page 9
Appendix B (Prize money tables)	page 11

1. The EHC – an EHF Sanctioned Competition

- 1.1** The EHC (European Handbike Circuit) is a series of events in the member countries sanctioned by the European Handcycling Federation (EHF).
- 1.2** Applications for sanctioning must be made direct to the EHF Committee by an EHF member nation on behalf of a race organiser.
- 1.3** An event may be a single race, a combination or series of races within one or more days.
- 1.4** EHC competitions are open for both able-bodied and disabled athletes from all nations.
- 1.5** All participating athletes are subject to the regulations of the EHF. In case of a UCI P1 event, the UCI rules shall apply. In case of contradiction, the UCI rules shall prevail.
- 1.6** All athletes must hold an international valid racing licence from their UCI recognised national cycling federation in UCI P1 EHC races. This license must be presented at all UCI competitions.
- 1.7** Antidoping: Drug tests may be carried out at any EHC competition. The refusal of an athlete to submit to these checks will be treated as if the athlete is tested positive.
- 1.8** Race organisers will pay a contribution from the entry fee on behalf of all participants to the EHF. The annual team registration fee is 100 Euros.

2. Classification

- 2.1** Every new athlete is responsible for their classification and is responsible to get in contact with the relevant EHF representative on this matter. Each new athlete not holding an official classification, can ask to receive a temporary classification; in this case it will be taken by the EHF representatives. This classification is only valid on EHC races and as long as the athlete is not UCI classified.
In case the new athlete doesn't ask for the temporary classification, he/she will be classified automatically in division HO.
For more information about UCI classification structure, look at the Paracycling regulations Chapter IV.
- 2.2** EHC follows the UCI para-cycling sport class profiles (Para-cycling regulations Article 16.5.001, 16.5.002, 16.5.003, 16.5.004, 16.5.005).
However, it differs in:
 - a. splitting division H1 in H1.1 and H1.2
(Notice: H1.1 are quads without or with only minimal triceps function)
 - b. able-bodied and unclassified athletes fall under EHF Open Division HO
- 2.3** Each division/subdivision is identifiable by the helmet (cover) colour, like noted on the UCI Para-cycling regulations Article 16.10.004.

- 2.4.** The helmet colour for EHC division H1.1 is blue with a yellow stripe
The helmet colour for EHC Open Division HO is black with a yellow stripe
- 2.5** Able-bodied athletes have the same rights and obligations as disabled athletes.

3. Time Keeping and Start Numbers

- 3.1** The chip for electronic time keeping must be fixed at the left hand side of the front axle & be in a vertical line with the front axle.
- 3.2.1** Loss or malfunction of the chip during road racing or criterium racing:
In the instance where the timing chip is lost, or there is a malfunction of the timing system, the responsibility lies with the athlete to provide indisputable proof of final placement.
- 3.2.2** If these issues are encountered during a time trial, there will be no way to calculate an accurate time and the individual athlete will therefore be disqualified.
- 3.3** At any EHC race, every rider will have 2 numbers on the helmet (one at each side) and 1 start number on the bike.

4. Individual ranking

- 4.1** Riders get EHC points for place 1 to 50 according to the following table:

place	points	place	points	place	Points	place	points	place	points
1	200	11	135	21	97	31	66	41	46
2	185	12	131	22	94	32	64	42	44
3	170	13	128	23	91	33	62	43	42
4	165	14	125	24	88	34	60	44	40
5	160	15	122	25	85	35	58	45	38
6	157	16	119	26	82	36	56	46	36
7	154	17	116	27	79	37	54	47	34
8	152	18	113	28	75	38	52	48	32
9	150	19	110	29	72	39	50	49	30
10	140	20	100	30	69	40	48	50	28

- 4.2** The ranking is based on the brutto-time of electronic time-keeping measurement which is provided by the event organiser.
- 4.3** Overall Ranking: The annual EHC series of races consist of 5 – 7 events. An event may be a single race, a combination or a number of races. The definite number of races which will count for the overall ranking will be announced at the beginning of the race season. The full points normally are available for each individual race with the only exception of Road Combined ranking (TT + RR).
The rider that accrues the most points is rewarded with the title ‘EHC Champion’ for that year.

- 4.4 The present points leader gets the Yellow Jersey at the victory ceremony.
- 4.5 The riders wearing the Champion Jersey are allowed to put their sponsors logos on the jersey, paying attention that EHF-EHC sponsor logos must remain in evidence. Athlete sponsors have not to be in contrast with EHF-EHC sponsors
- 4.6 The points leader only loses the jersey if their next competitor gets more points in the overall ranking.
- 4.7 Any athlete, who changes from one division to another during the race season for whatever reason, cannot carry their points across. This also applies to athletes who have yet to attain their final decision on classification.
- 4.8 In the case of not more than two participants in any division, such participants shall be merged with the next higher (sub)division. The EHC points will be awarded to the (sub)division in which the athlete is classified.

5. Team Ranking

- 5.1 A team is up to a maximum of 8 riders and at least 4 riders shall start in a race in order to attain points. The annual participation fee is 100 Euros per team.
- 5.2 A team shall be composed of athletes from different divisions.
- 5.3 Changing of team members is not permitted throughout the year. But uncommitted athletes may join a team until the quota is filled.
- 5.4 Points will be counted from the best four handbikers of a team who finish (max. 800 points). In order to attribute points, all classes will be considered.
- 5.5 Only in the case of a tie of two or more teams the team with the faster accrued time beats the slower one. Ranking will be defined from the total sum of the individual race times of each athlete considered valid about point attribution.
- 5.6 When two or even one rider of a team finish, their points will be counted as well for the team.
- 5.7 The number of races which will count for overall ranking will be announced at the beginning of the race season.
- 5.8 A team shall be recognised by identical race-suits.

6. Handbike equipment

6.1 EHC-rule on handbike-equipment corresponds to UCI Para-cycling regulations Chapter XVII

7. Safety

7.1 In road races, the wearing of a rigid safety helmet, to international UCI standard for cycle racing, is compulsory for all athletes. No helmet – no start!
Athletes using the wrong color helmet in road races will not be allowed to start and/or will be withdrawn from the race and disqualified.

7.2 Aerodynamic time-trial helmets are only permitted in time-trials.

7.3 Race approval of a handcycle may be denied, if certain parts on an athletes handcycle could potentially endanger the rider or their competitors.

7.4 If a handcycle is damaged during the race & potentially doesn't fulfil equipment regulations

- a. the athlete is obliged to stop to repair their equipment or to withdraw.
- b. the organiser is entitled to stop the athlete for repair or to withdraw them from the race.

8. Races

8.1 The EHC offers 5 types of races:

- a. Road Race
- b. Individual Time Trial (ITT)
- c. Criterium
- d. Combination of ITT and RR or Combination of ITT and Criterium
- e. Team Time Trial (TTT)

8.2 Combination:
The ranking will be determined with points as follows: The winner gets one point, the second 2 points... and so on. To calculate the combined ranking the points of each race are added.
Total number of points - the less the merrier.
Athletes who did not finish (DNF) or start (DNS) in both races get no points.

8.3 Team Time Trial
Team composition: Athletes from different levels of disability and gender are working together.

A team consists of three riders. The teams are commercial or club teams – no national teams!
There is a point scale depending on disability and gender as follows:

Division	Men points	Women points
H1.1/2	1	1
H2	2	1
H3	3	2
H4/HO	3	2

8.3.1 There are two different classes of teams:

Team 6: A maximum of 2 athletes can have the same value of points. The total of points of the three riders must be at maximum of six.

Team 8: A maximum of 2 athletes can have the same value of points. The total of points of the three riders must be at maximum of eight.

8.3.2 The time of the slowest rider of the team shall always count. To be ranked all 3 riders have to finish.

8.4 Starting position depends on the EHC overall ranking list until place 10. The starting position between place 10 and 15 is reserved for wellknown fast riders off top 10 ranking. All riders are obliged to be present at the starting line 15 minutes before the start, otherwise they have to start at the end of the division.

8.5 Between each division start (MH4 – MH3 – MH2 – MH1 mixed - WH1-4 - M/WHO) there has to be a break of at least one minute. It is also possible to organise a separate race for each division.

8.6 It is forbidden to draft behind riders from another division or behind athletes from another category (wheelchair racers, inline skaters etc). The drafting zone is 6,0 metres long. Notice: Drafting between classes H1.1 and H1.2 is allowed!
For more information see appendix A!

9. Penalties

9.1 In UCI sanctioned EHC competitions any participant who commits an infraction of regulations will be subject to the disciplinary procedures and sanctions of the UCI. In EHC races that are not UCI sanctioned the EHF Jury will decide about appropriate penalties.

10. Prize money

10.1 The prize money for the winner will not be distributed unless at least 3 athletes participated in the class.

The prize money for the best 2 athletes will not be distributed unless at least 4 athletes participated in the class.

The prize money for the best 3 athletes will not be distributed unless at least 5 athletes participated in the class.

(Distributing table see Appendix B)

10.2 At the end of the EHC series, the EHF Committee will distribute prize money for the best places in the overall ranking.

10.3 Non-participation at the victory ceremonies will cause loss of prize money for the benefit of the EHF.

10.4 Should the ranking be rectified, prizes already awarded shall be returned and given to the entitled athletes according to the revisited rankings.

11. U 23 Athletes

11.1 U23 athletes need not to pay race registration fees

11.2 The best ranked U23 athlete of each division in the overall ranking will receive prize money specified at the end of the racing season and U23 trophies.

11.3 The best ranked U23 athlete of each division may receive prize money from the organizers of the individual events.

12. Exclusion of liability

12.1 With your participation to one or more races and additional events of the EHC, you acknowledge the liability-exclusion of the EHF-Committee or of involved third-party for personal or material damage.

EHF Committee
December 2009

APPENDIX A

Drafting, what is it and how can you avoid forbidden drafting? Drafting is the act of riding behind another handcyclist in an area of reduced air pressure created in the wake of that leading handcyclist. The trailing or drafting handcyclist uses less energy to maintain the same speed as the handcyclist they are trailing. Of course - drafting within a group of riders of the same division is allowed and an important part of racing, but drafting another handcyclist of different division during an EHC race is outright illegal and creates an unfair advantage. So, let's focus on how we can avoid drafting between different divisions and the time penalties and disqualifications associated with it.

Practice good sportsmanship at all times!

Drafting rule *(Appendix of rule 8.6)*

- a) Drafting off a **competitor of another division** is forbidden (except in team trials). All competitors must reject any attempt by others to draft.
- b) The draft zone is defined as a rectangle, 6 metres long (the length of about 3 handcycles) by 2 metres wide, surrounding every competitor. The trailing edges of the leading handcycle's back wheels define the beginning of the 6 metre length, which ends at the leading edge of the trailing handcycle's front wheel. The front wheel divides the short side of the zone into two equal parts, each being one metre wide.
- c) The cyclist who has been "overtaken" bears primary responsibility for avoiding a position foul and must immediately move to the side or to the rear and out of the drafting zone of the passing handcyclist.

Two examples of forbidden drafting



Pic 1: Two H2 riders directly behind one H4 rider



Pic 2: Two H4 riders behind one H2 rider

The drafting dilemma

Many athletes are frustrated by the blatant and continued disregard some race participants have for this rule. The rule is easy to understand and the different divisions can be recognised by the helmet colours.

There is no doubt that even a brief period of drafting gives an athlete a distinct advantage. 60-80 percent of resistance on the handbike comes from the air in front of a handcyclist. By having another handcyclist block this air flow, the amount of energy an athlete has to expend is drastically reduced.

In a large pack of riders, a handcyclist can motor at speeds much greater than would be sustainable under their own power. Furthermore drafting leaves the arms nice and fresh for the sprints.

You can imagine the annoyance an athlete feels when they are passed by a rival „pulled“ by a rider from another division in flagrant disregard for this rule. Particularly at the time when you had already personal success in moving away from that rival before.

These athletes may have worked hard for months, or, perhaps, an entire season to be at their best for a race. Their goals could include attempting to qualify for a coveted event slot or accumulate points in the EHC series. Losing to someone who cheated can leave a very bitter taste in your mouth and even question the legitimacy of the sport.

The most responsibility rests on the athletes themselves. There is a "herd" mentality and the more drafting that occurs, the more drafting will occur. If you were to ask an athlete why they were drafting a typical response would be "the course was congested, and I could not pass." Some courses are very congested but this does not keep an athlete from dropping back out of the draft zone!

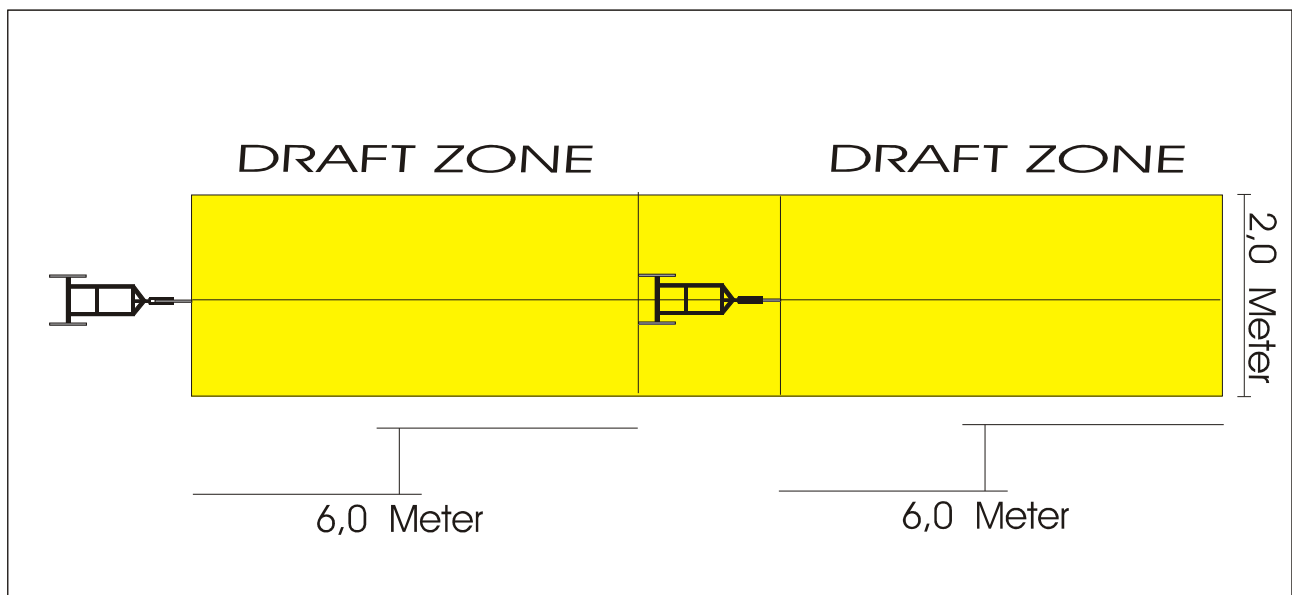

APPENDIX B

I. Distributing table of prize money¹ for EHC single events (€ 3640,00)

	MH1.1	MH1.2	MH2	MH3	MH4	MH0	WH1	WH2	WH3	WH4	WHO	Teams
1	150	150	200	200	150	150	0	150	150	150	0	150
2	100	100	150	150	100	100		100	100	100		
3	50	50	120	120	50	50		50	50	50		
4			100	100								
5			75	75								
6			50	50								
	300	300	695	695	300	300	0	300	300	300	0	150

II. Distributing table of prize money¹ for EHC combination events (€ 5445,00)

	MH1.1	MH1.2	MH2	MH3	MH4	MH0	WH1	WH2	WH3	WH4	WHO	Teams
1	225	225	300	300	225	225	0	225	225	225	0	225
2	150	150	225	225	150	150		150	150	150		
3	75	75	180	180	75	75		75	75	75		
4			150	150								
5			110	110								
6			70	70								
	450	450	1035	1035	450	450	0	450	450	450	0	225

III. Distributing table of prize money for EHC overall ranking (€ 9000,00)

	MH1.1	MH1.2	MH2	MH3	MH4	MH0	WH1	WH2	WH3	WH4	WHO	Teams
1	250	325	500	500	325	250	75	300	300	300	75	400
2	175	225	350	350	225	175		175	175	175		300
3	75	150	225	225	150	75		75	75	75		200
4		100	200	200	100							100
5			150	150								0
6			125	125								0
7			100	100								
8			75	75								
9			50	50								
10			25	25								
	500	800	1800	1800	800	500	75	550	550	550	75	1000

Notice: The prize money will be distributed according to EHF rule (Rulebook § 10)

¹ This is the minimum prize money which can be expected. The event organiser is free to pay more